

SECTION 2

RADIATOR / OIL COOLER

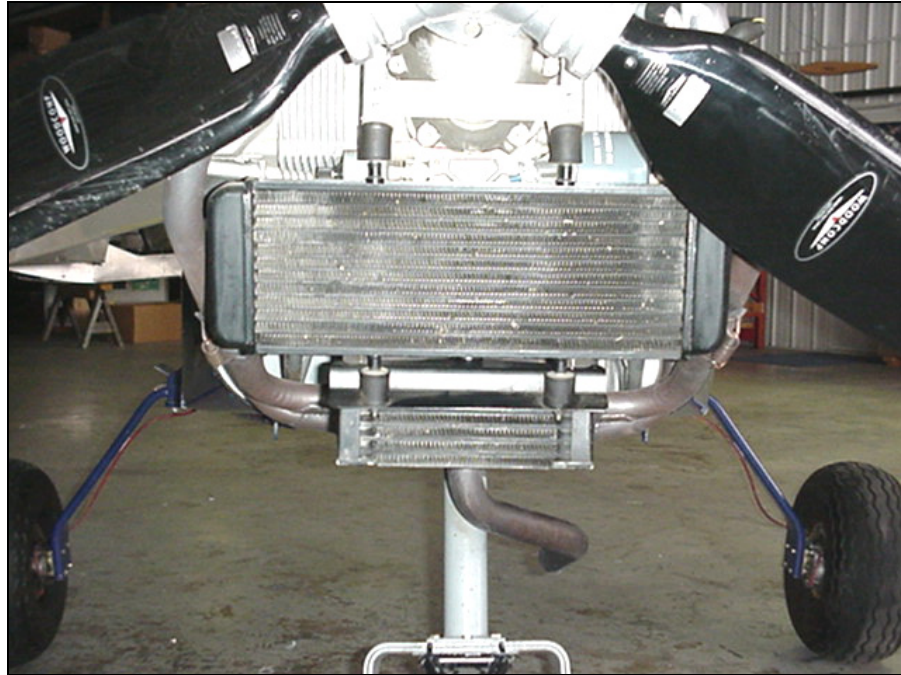

- Rotax radiator inside cowl (front)
- Rotax oil cooler (underneath radiator)

995-697	RADIATOR	1
----------------	-----------------	----------

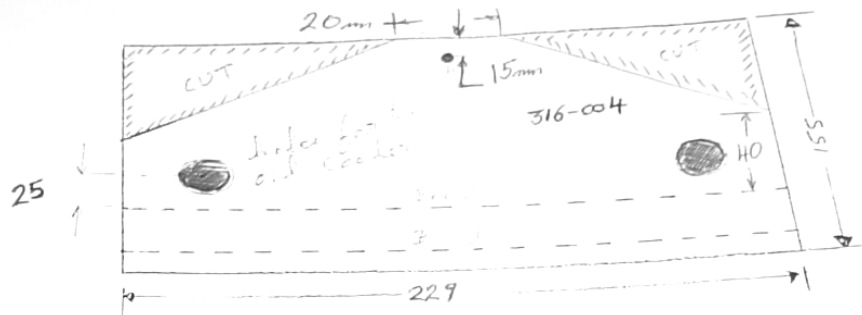

L = 229 mm
 W = 155 mm
 t = .090 STEEL

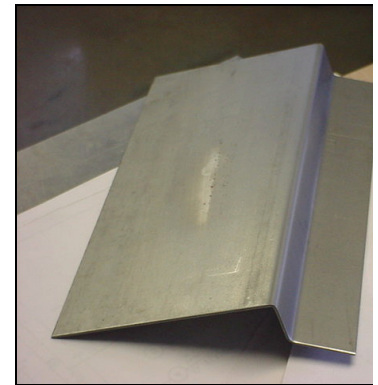
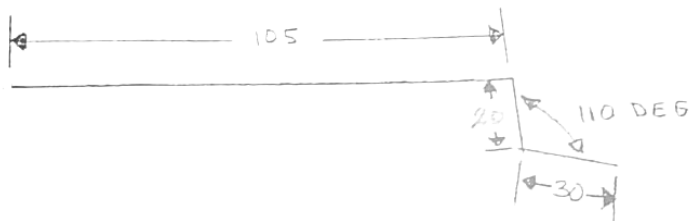

79-CB
 COOLING BRACKET
 .090" steel

ORIENTATION: The flange is toward the bottom.

Drill two 5.9mm holes for the Vibro Stops in the front flange, distance between centers is 151mm (Check with radiator).

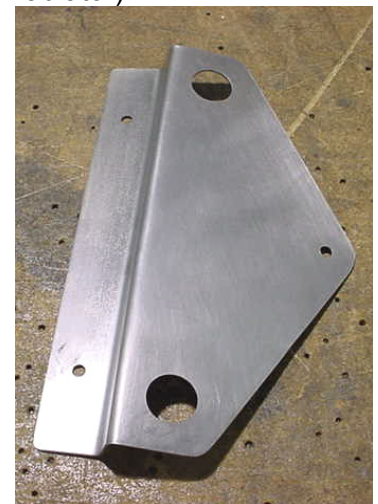

79-CB
 COOLING BRACKET

NOTE: part is symmetrical from center-line.

Drill one 5.9mm hole (for Vibro Stop 316-004) 15mm forward of the aft edge. Drill two 7/8" holes (for the oil cooler) 25mm back from the top bend, 180mm between centers (check with oil cooler).

316-004 VIBRO STOP
M6 SELF LOCKING
NUT

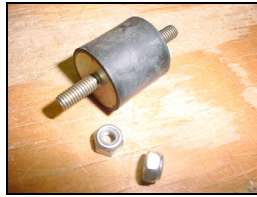

Qty = 1

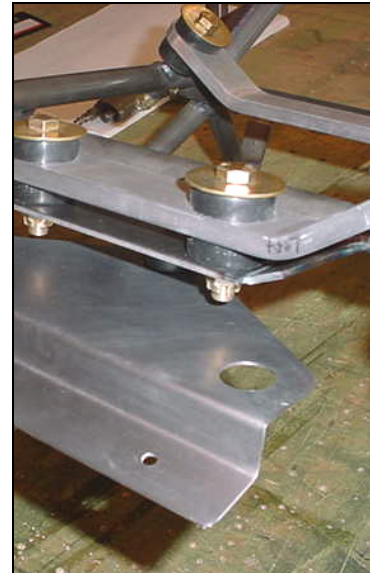

Refer to the radiator for the spacing for the two holes in the front flange.

Photo looking up from underneath the engine mount.

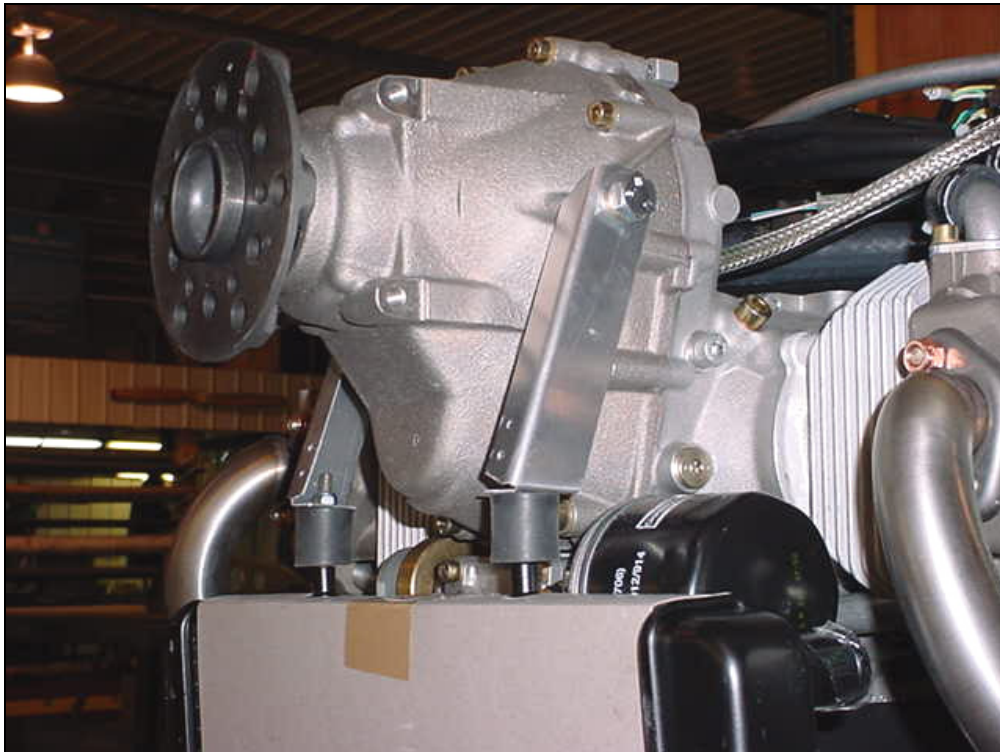

VIBRO STOP
316-004

Nut M22
156-088

Screw the 4 vibro stops on radiator.

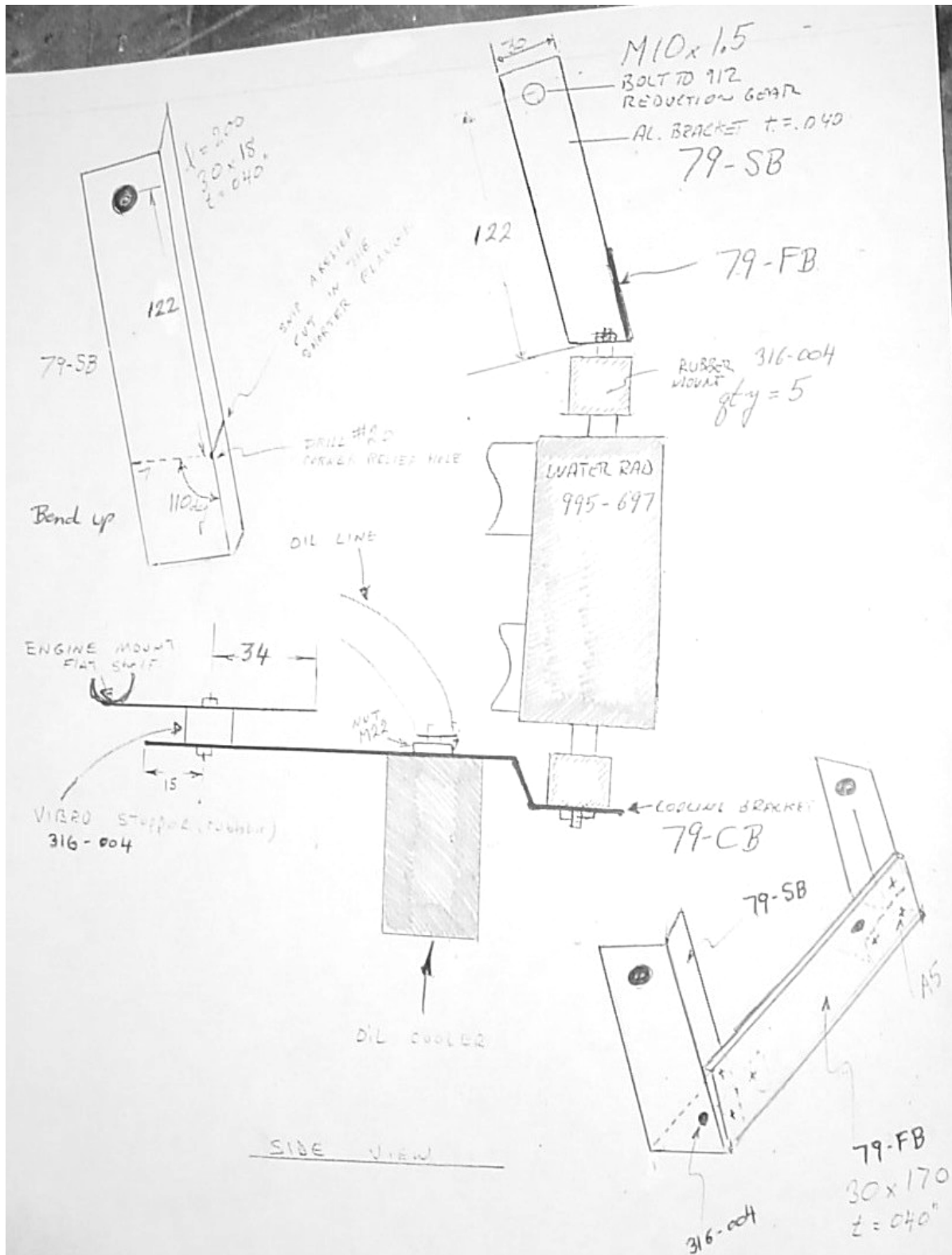

Installation of Cooling Bracket 79-CB to the front "tray" on the engine mount.
 5.9mm hole on center line of the engine, 34mm from the front edge of the "tray" welded at the front of the engine mount 7E1-1R

**ALUMINUM BRACKET
79-SB**



From the center of the #20 hole, draw a line on the 30mm flange at 110 degrees

30x18mm flanges, length = 200mm, t=.040" 6061-T6
Drill a #20 hole in the radius 140mm from the top of the bracket.
With the hand snips cut a slot square to the 20mm flange.



Cut off the 20mm flange along the bend.



Left and right brackets required.

Clamp in a vise and fold over.
IMPORTANT: bend radius = 1/8" If necessary file a radius on a board, then clamp the Bracket and board in the vise. Bend the Bracket over the filed radius.
NOTE: IT IS ALSO ACCEPTABLE TO BEND WITHOUT FIRST CUTTING OFF THE 20MM FLANGE



Drill a 10mm hole
File and radius the
corners.



Ref. Distance is measured along the bend.
Layout: From the bottom flange, measure up 122mm, with a square mark a
line across the 30mm flange.



Drill a 6mm hole in the
middle of the bottom
flange for the Vibro Stop.

Trim the bottom flange
20mm wide.

Bolt the **79-SB** Vibro Stop
on the radiator.

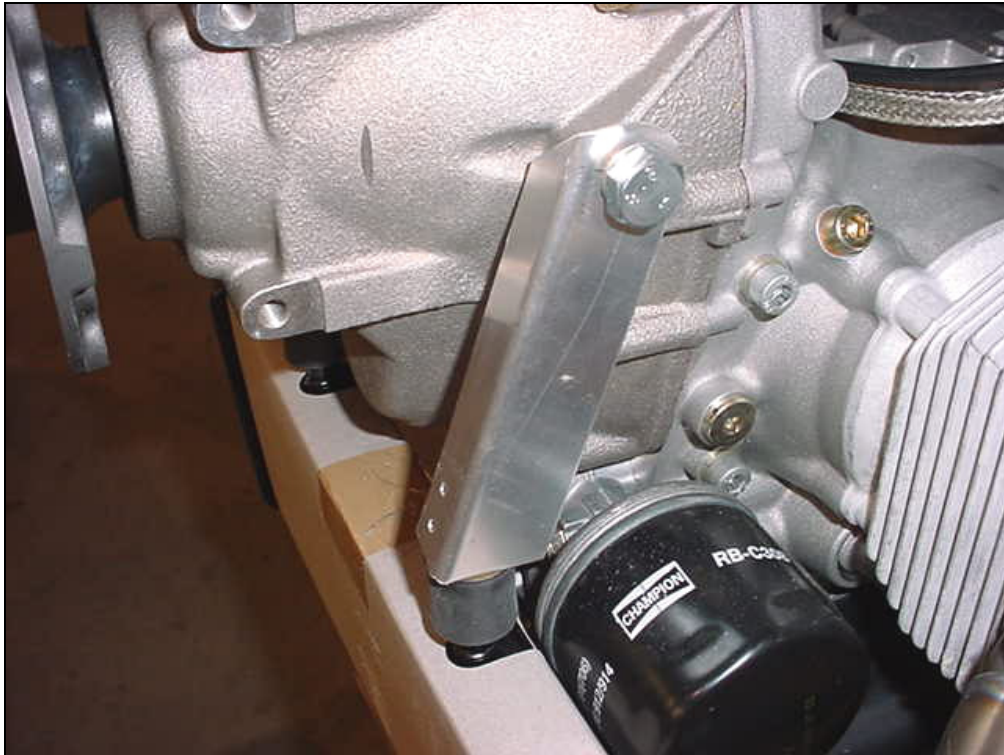

Bolt the Radiator assembly to the existing **tapped holes in the gear reduction unit.**



Trim back the top corner of the 20mm flange.

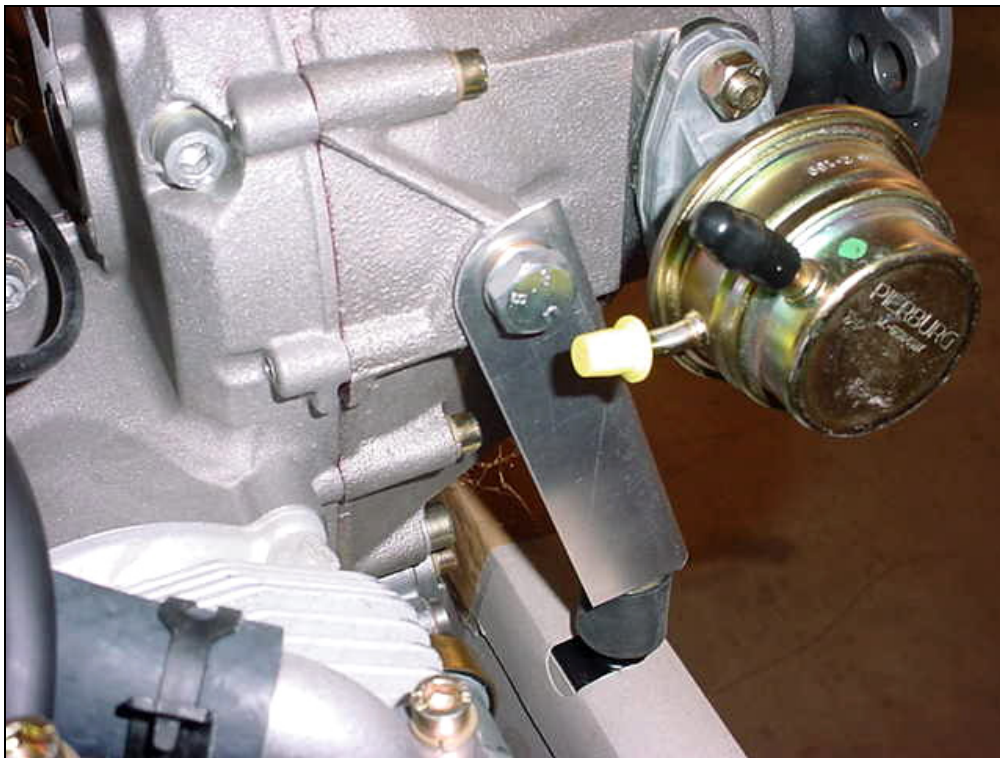

Right side, Notice the fuel pump.

M10x1.5
BOLT IN EXISTING
TAPPED HOLE IN
REDUCTION GEAR.



Screw the bottom Vibro Stops to the Cooling Bracket 79-CB



Side view of the Cooling Bracket to support the bottom of the rad to the engine mount.

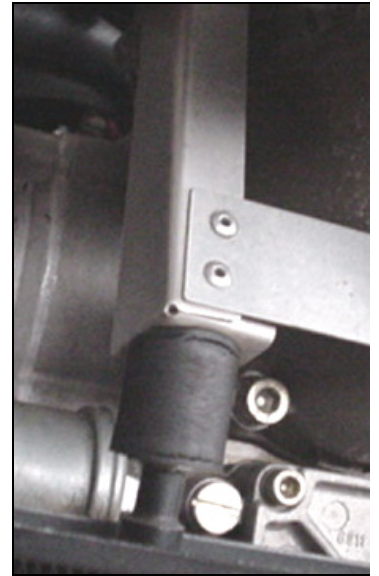
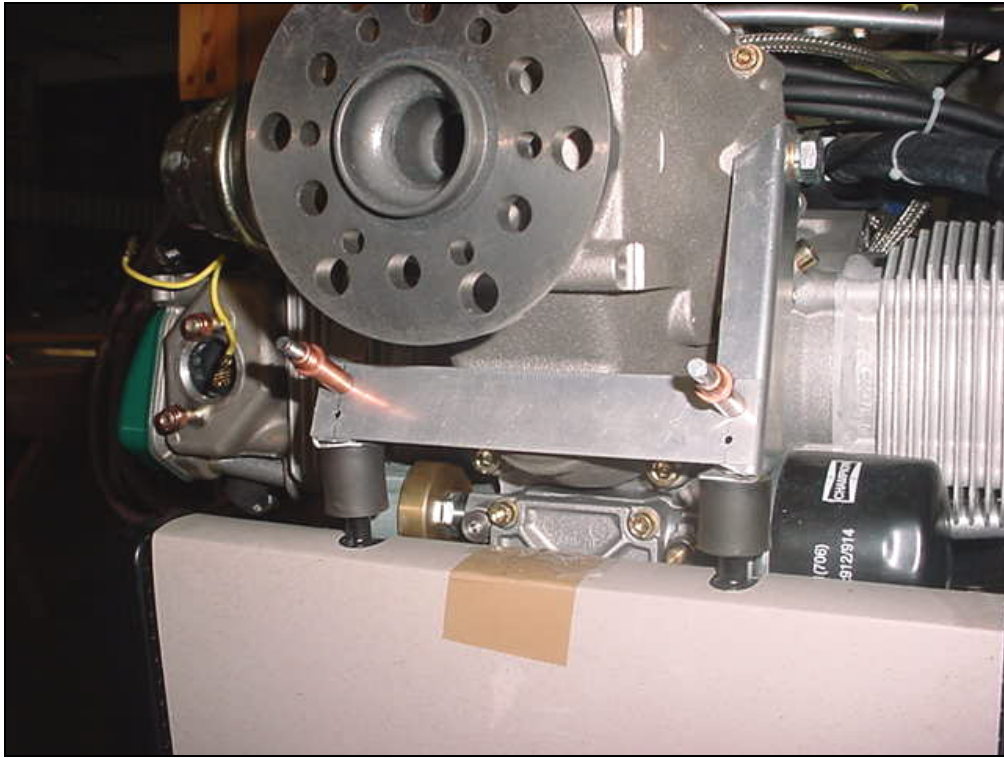

2 RIVETS A5
79-BF into 79-SB

FRONT BRACKET FLAT 79-FB (6061-T6 t=.040")

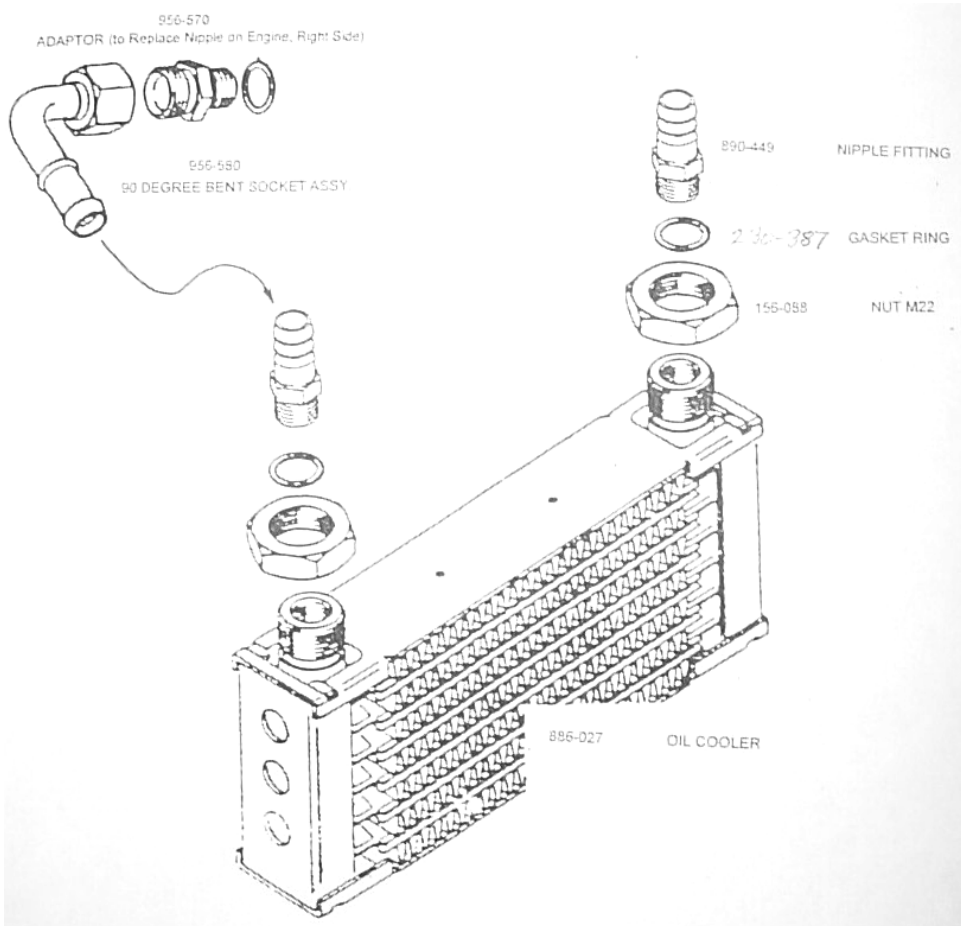

Rotax oil cooler 886-027
Size: 82mm 3.32"

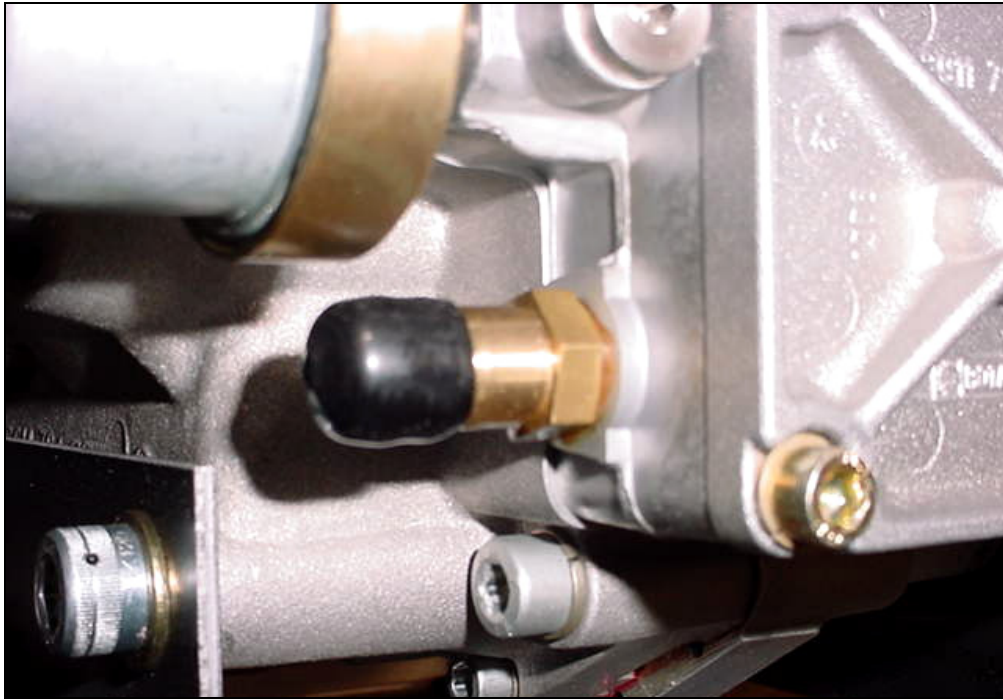

**STRAIGHT NIPPLE
FITTING
890-449**

Locate the nipple fitting below the oil pressure sender unit on the front right of the engine.

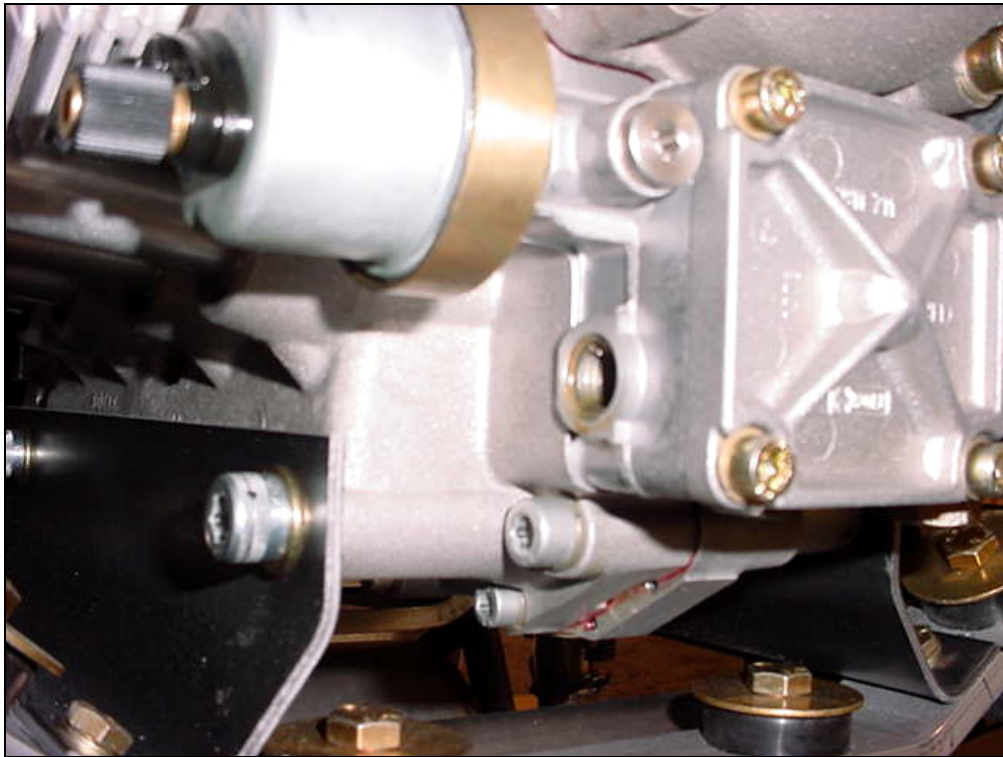

**ADAPTOR
956-570**

**GASKET RING
230-387**

**90 DEGREE BENT
SOCKET ASSY.
956-580**



Unscrew the nipple fitting from the engine. Keep this part, it will be used on the oil cooler.

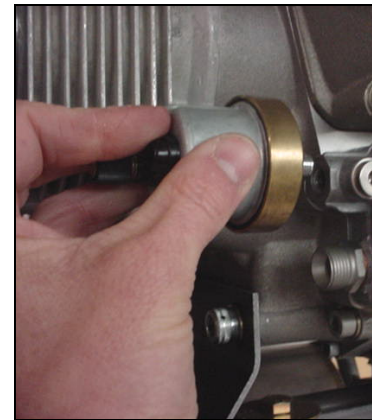
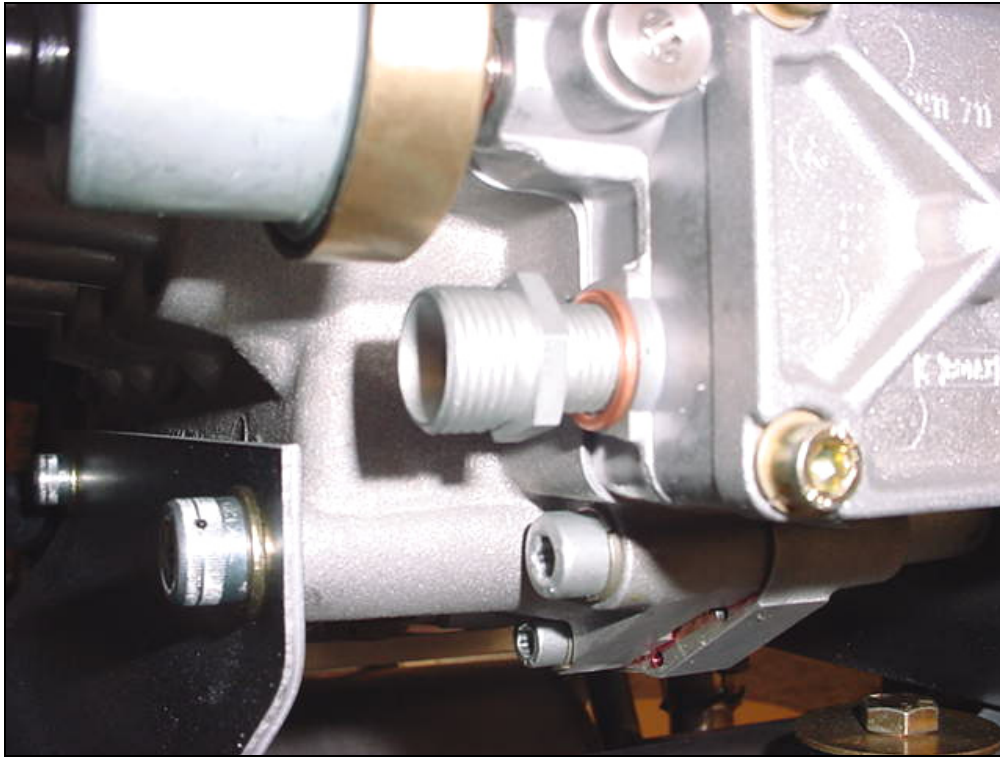

Unscrew the oil pressure sender unit to install the 90 degree bent socket assembly

Add the gasket ring 230-387 to the Adaptor 956-570, screw on engine in place of the nipple fitting 890-449

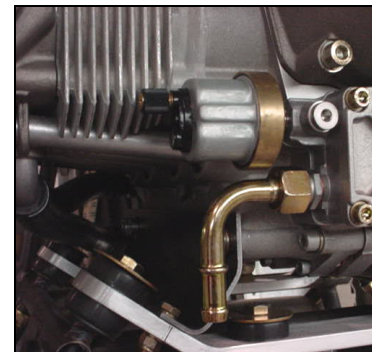
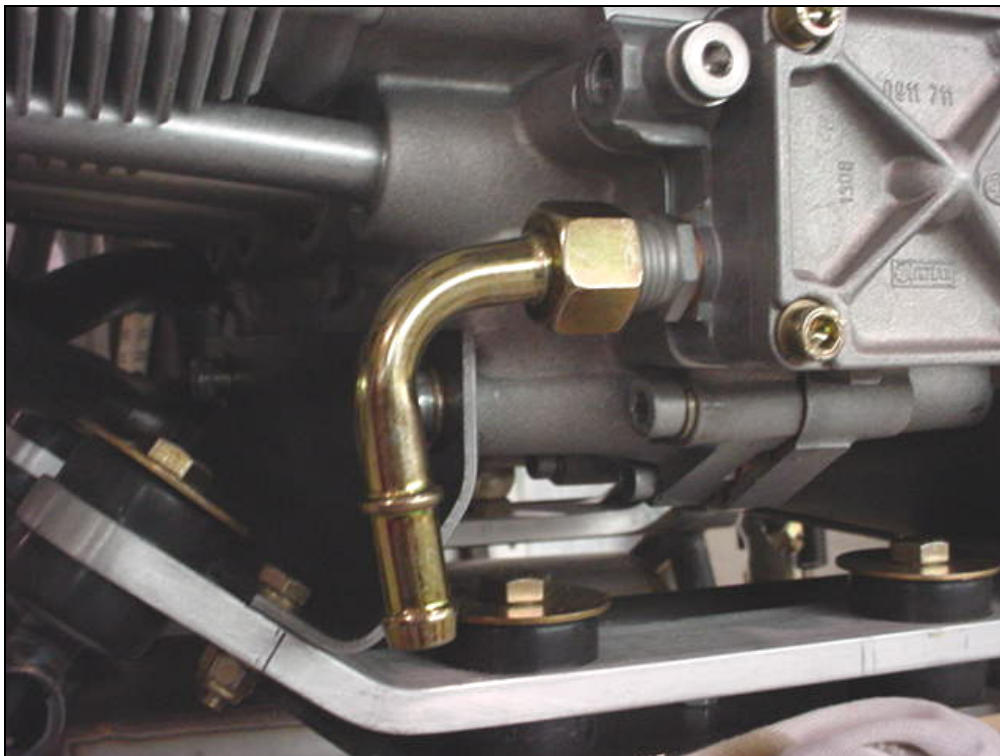

Reinstall the oil pressure sender unit.

Screw the 90 degree bent socket assembly 956-580 to the adaptor 956-570



NIPPLE FITTINGS
890-449

GASKET RING
230-387

Rotax oil cooler 886-027



NUT M2
156-088

Nuts to bolt the oil cooler to
the Bracket 79-CB

Add the Gasket ring to the nipple fitting and screw the fitting inside the threaded portion of the oil cooler